

# JVC



## CD RECEIVER

## KD-G498

ENGLISH

## เครื่องเล่น CD

## KD-G498

ไทย

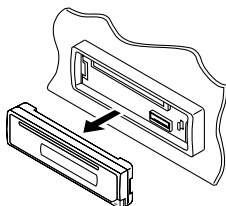
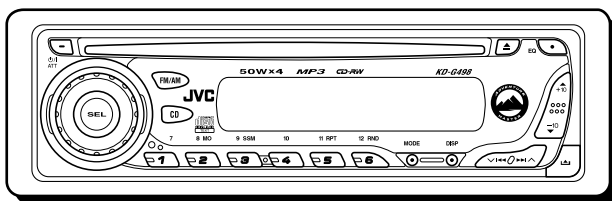
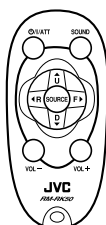

### MP3 CD-RW



- This unit is equipped with the display demonstration. To cancel it, see page 8.
- เครื่องนี้ได้รับการติดตั้งการสาธิตภาพประกอบ หากต้องการยกเลิก โปรดดู หน้า 8

For installation and connections, refer to the separate manual.

กรุณาดูคู่มือที่แยกต่างหาก ในการติดตั้งและการเชื่อมต่อ

# INSTRUCTIONS

## คำแนะนำ

GET0292-001A  
[UH]

## IMPORTANT FOR LASER PRODUCTS

1. CLASS 1 LASER PRODUCT
2. **CAUTION:** Do not open the top cover. There are no user serviceable parts inside the unit; leave all servicing to qualified service personnel.
3. **CAUTION:** Visible and invisible laser radiation when open and interlock failed or defeated. Avoid direct exposure to beam.
4. REPRODUCTION OF LABEL: CAUTION LABEL, PLACED OUTSIDE THE UNIT.

<p><b>CAUTION:</b> Visible and invisible laser radiation when open and interlock failed or defeated. AVOID DIRECT EXPOSURE TO BEAM.</p>	<p><b>ADVARSEL:</b> Synlig og usynlig laserstråling når maskinen er åpen eller interlocken fejler. Undgå direkte eksponering til stråling.</p>	<p><b>WARNING:</b> Synlig och osynlig laserstråling när den öppnas och spärran är urkopplad. Beträkta ej strålen.</p>	<p><b>VARO:</b> Avattassa ja suojalukitus ohjettuna tai viallisena olet alitina näkyväille ja näkymättömälle lasersäteilylle. Vältä säteen kohdistumista suoraan itseesi. (f)</p>
---	--	---	---

### How to reset your unit

While holding SEL (select), press  $\Phi$ /I ATT (standby/on attenuator) for more than 2 seconds. This will reset the built-in microcomputer.

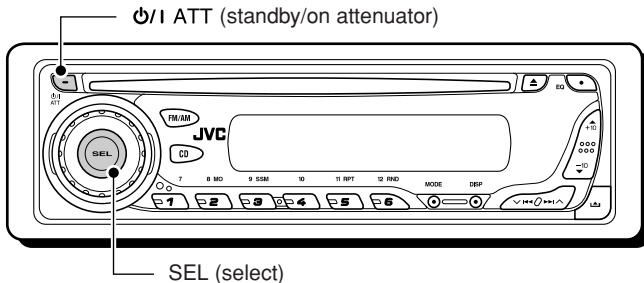

#### Notes:

- Your preset adjustments—such as preset channels or sound adjustments—will also be erased.
- If a disc is in the unit, it will eject when you reset the unit. Be careful not to drop the disc.

### How to forcibly eject a disc

While holding  $\Phi$ /I ATT (standby/on attenuator), press  $\blacktriangle$  (eject) for more than 2 seconds until the disc is ejected from the loading slot, if a disc cannot be recognized by the unit or cannot be ejected.

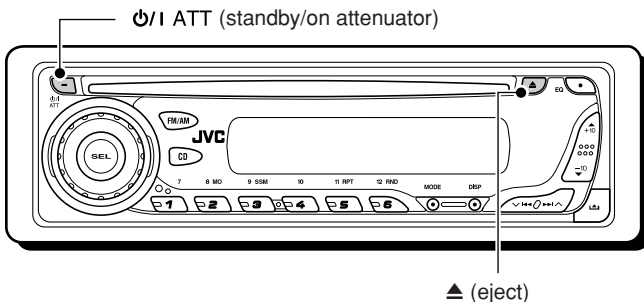

#### Notes:

- If this does not work, try to reset your unit.
- Be careful not to drop the disc when it ejects.

Thank you for purchasing a JVC product. Please read all instructions carefully before operation, to ensure your complete understanding and to obtain the best possible performance from the unit.

# CONTENTS

How to reset your unit .....	2	<b>MP3 OPERATIONS .....</b>	<b>18</b>
How to forcibly eject a disc .....	2	Playing an MP3 disc .....	18
How to use the MODE button .....	3	Locating a file or a particular portion on an MP3 disc .....	19
<b>LOCATION OF THE BUTTONS .....</b>	<b>4</b>	Selecting MP3 playback modes .....	21
Control panel .....	4	<b>SOUND ADJUSTMENTS .....</b>	<b>22</b>
Remote controller .....	5	Selecting preset sound modes (C-EQ: custom equalizer) .....	22
Preparing the remote controller .....	6	Adjusting the sound .....	23
<b>BASIC OPERATIONS .....</b>	<b>7</b>	<b>OTHER MAIN FUNCTIONS .....</b>	<b>24</b>
Turning on the power .....	7	Changing the general settings (PSM) .....	24
Canceling the display demonstration .....	8	Detaching the control panel .....	26
Setting the clock .....	9	<b>ADDITIONAL INFORMATION .....</b>	<b>27</b>
<b>RADIO OPERATIONS .....</b>	<b>10</b>	Playing a CD-R or CD-RW .....	27
Listening to the radio .....	10	Playing an MP3 disc .....	27
Storing stations in memory .....	12	<b>TROUBLESHOOTING .....</b>	<b>28</b>
Tuning in to a preset station .....	13	<b>MAINTENANCE .....</b>	<b>30</b>
<b>CD OPERATIONS .....</b>	<b>14</b>	<b>SPECIFICATIONS .....</b>	<b>31</b>
Playing a CD .....	14		
Locating a track or a particular portion on a CD .....	15		
Selecting CD playback modes .....	16		
Playing a CD Text .....	17		
Prohibiting disc ejection .....	17		

## How to use the MODE button

If you press MODE, the unit goes into functions mode, then the number buttons and ▲/▼ buttons work as different function buttons.

Ex.: When number button 2 works as MO (monaural) button.

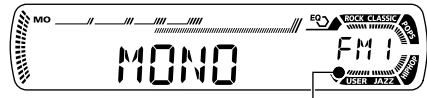
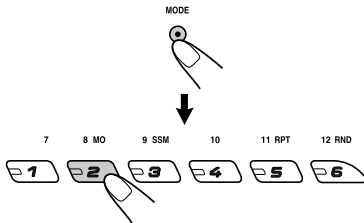

Time countdown indicator

To use these buttons for original functions again after pressing MODE, wait for 5 seconds without pressing any of these buttons until the functions mode is cleared.

- Pressing MODE again also clears the functions mode.

## BEFORE USE

### \*For safety....

- Do not raise the volume level too much, as this will block outside sounds, making driving dangerous.
- Stop the car before performing any complicated operations.

### \*Temperature inside the car....

If you have parked the car for a long time in hot or cold weather, wait until the temperature in the car becomes normal before operating the unit.



# LOCATION OF THE BUTTONS

ENGLISH

## Control panel

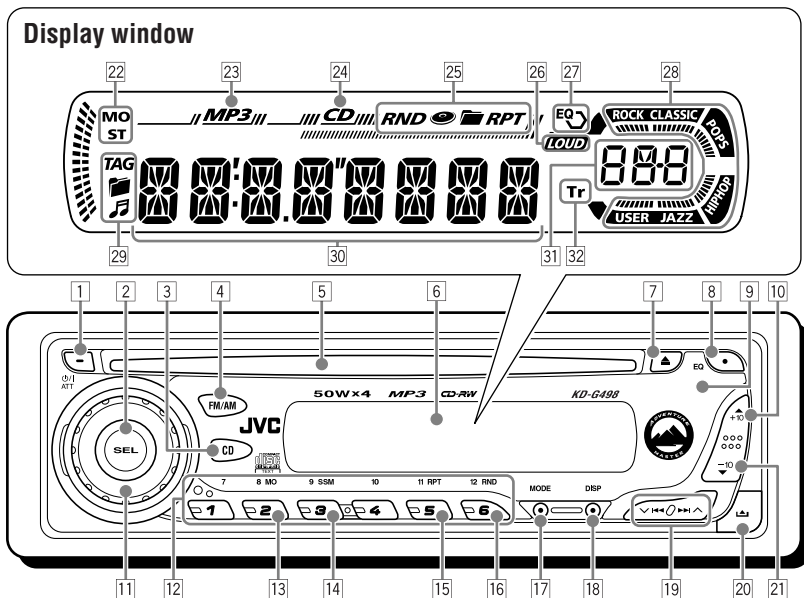

- 1  $\phi$ /I ATT (standby/on attenuator) button
- 2 SEL (select) button
- 3 CD button
- 4 FM/AM button
- 5 Loading slot
- 6 Display window
- 7  $\blacktriangle$  (eject) button
- 8 EQ (equalizer) button
- 9 Remote sensor
- 10  $\blacktriangle$  (up) button  
+10 button
- 11 Control dial
- 12 Number buttons
- 13 MO (monaural) button
- 14 SSM (Strong-station Sequential Memory) button
- 15 RPT (repeat) button
- 16 RND (random) button
- 17 MODE button
- 18 DISP (display) button
- 19  $\blacktriangledown$   $\leftarrow$   $\rightarrow$   $\blacktriangleright$   $\blacktriangle$  buttons
- 20  $\blacktriangle$  (control panel release) button
- 21  $\blacktriangledown$  (down) button  
-10 button

## Display window

- 22 Tuner reception indicators  
MO (monaural), ST (stereo)
- 23 MP3 indicator
- 24 CD indicator
- 25 Playback item/mode indicators  
RND (random), (disc), (folder), RPT (repeat)
- 26 LOUD (loudness) indicator
- 27 EQ (equalizer) indicator
- 28 Sound mode (C-EQ: custom equalizer) indicators  
ROCK, CLASSIC, POPS, HIP HOP, JAZZ, USER
  - also works as the time countdown indicator.
- 29 Disc information indicators  
TAG (ID3 Tag), (folder), (track/file)
- 30 Main display
- 31 Source display  
Volume level indicator
- 32 Tr (track) indicator



# Remote controller

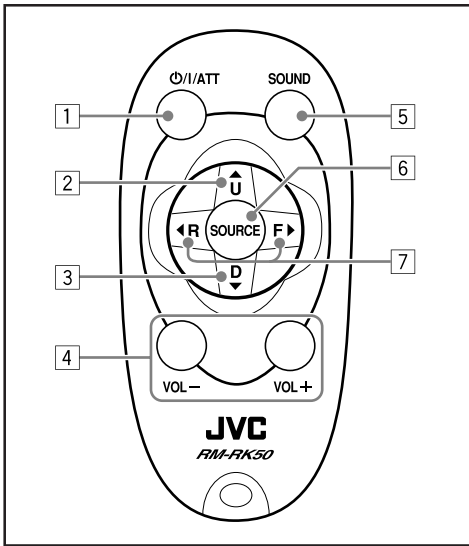

- 1 • Turns on the unit if pressed when the unit is turned off.
  - Turns off the unit if pressed and held until “SEE YOU” appears on the display.
  - Drops the volume level in a moment if pressed briefly.  
Press again to resume the volume.
- 2 • Selects the band while listening to the radio. Each time you press the button, the band changes.
  - Skips to the first file of the next folder while listening to an MP3 disc. Each time you press the button, you can move to the next folder and start playing the first file.

- 3 • Selects the preset stations while listening to the radio. Each time you press the button, the preset station number increases, and the selected station is tuned in.
  - Skips to the first file of the previous folder while listening to an MP3 disc. Each time you press the button, you can move to the previous folder and start playing the first file.
- 4 Functions the same as the control dial on the main unit.

**Note:** These buttons do not function for the preferred setting mode (PSM) adjustment.
- 5 Selects the sound mode (C-EQ: custom equalizer). Each time you press the button, the sound mode (C-EQ) changes.
- 6 Selects the source. Each time you press the button, the source changes.
- 7 • Searches for stations while listening to the radio.
  - Fast-forwards or reverses the track/file if pressed and held while listening to a disc.
  - Skips to the beginning of the next track/file or goes back to the beginning of the current (or previous) tracks/files if pressed briefly while listening to a disc.

## Preparing the remote controller

Before using the remote controller:

- Aim the remote controller directly at the remote sensor on the main unit. Make sure there is no obstacle in between.

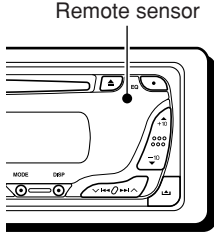

- Do not expose the remote sensor to strong light (direct sunlight or artificial lighting).

### Installing the battery

When the controllable range or effectiveness of the remote controller decreases, replace the battery.

#### 1. Remove the battery holder.

- 1) Push out the battery holder in the direction indicated by the arrow using a ball-point pen or a similar tool.
- 2) Remove the battery holder.

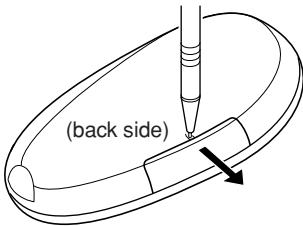

#### 2. Place the battery.

Slide the battery into the holder with the + side facing upwards so that the battery is fixed in the holder.

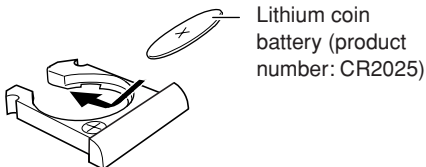

#### 3. Return the battery holder.

Insert again the battery holder by pushing it until you hear a clicking sound.

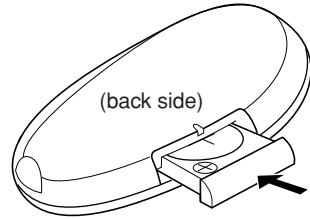

#### WARNING:

- Store the battery in a place where children cannot reach.  
*If a child accidentally swallows the battery, consult a doctor immediately.*
- Do not recharge, short, disassemble, or heat the battery or dispose of it in a fire.  
*Doing any of these things may cause the battery to give off heat, crack, or start a fire.*
- Do not leave the battery with other metallic materials.  
*Doing this may cause the battery to give off heat, crack, or start a fire.*
- When throwing away or saving the battery, wrap it in tape and insulate; otherwise, the battery may start to give off heat, crack, or start a fire.
- Do not poke the battery with tweezers or similar tools.  
*Doing this may cause the battery to give off heat, crack, or start a fire.*

#### CAUTION:

*DO NOT leave the remote controller in a place (such as dashboards) exposed to direct sunlight for a long time. Otherwise, it may be damaged.*

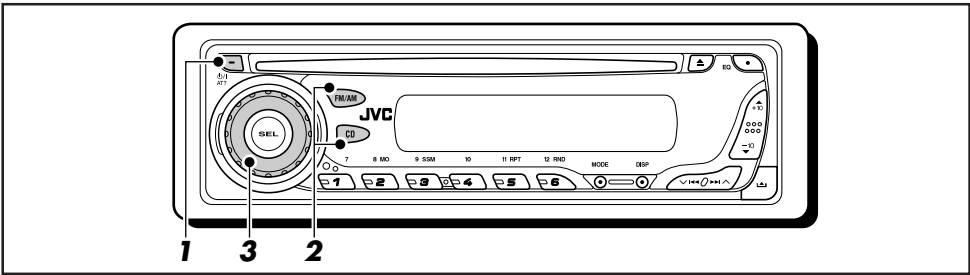

## Turning on the power

### 1 Turn on the power.



#### Note on One-Touch Operation:

When you select a source in step 2 below, the power automatically comes on. You do not have to press this button to turn on the power.

### 2 Select the source.

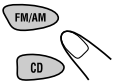

- To operate the tuner (FM or AM), see pages 10 – 13.
- To play a CD, see pages 14 – 17.
- To play an MP3 disc, see pages 18 – 21.

### 3 Adjust the volume.

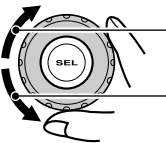

To increase the volume

To decrease the volume

Volume level appears.

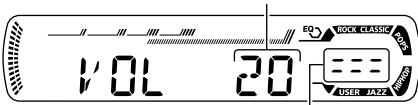

Volume level indicator

### 4 Adjust the sound as you want. (See pages 22 and 23.)

#### To drop the volume in a moment

Press **ATT** briefly while listening to any source. "ATT" starts flashing on the display, and the volume level will drop in a moment.

To resume the previous volume level, press the button briefly again.

- If you turn the control dial, you can also restore the sound.

#### To turn off the power

Press and hold **ATT** for more than one second.

"SEE YOU" appears, then the unit turns off.

- **If you turn off the power while listening to a disc**, disc play will start from where playback has been stopped previously, next time you turn on the power.

#### CAUTION on Volume Setting:

Discs produce very little noise compared with other sources. If the volume level is adjusted for the tuner, for example, the speakers may be damaged by the sudden increase in the output level. Therefore, lower the volume before playing a disc and adjust it as required during playback.

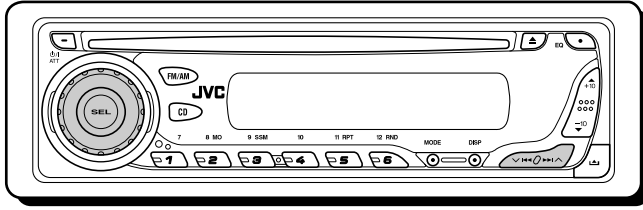

## Canceling the display demonstration

When shipped from the factory, display demonstration has been activated, and starts automatically when no operations are done for about 20 seconds.

- It is recommended to cancel the display demonstration before you use the unit for the first time.

To cancel the display demonstration, follow the procedure below:

- Press and hold SEL (select) for more than 2 seconds so that one of the PSM items appears on the display. (PSM: see page 24.)



- Select "DEMO" if not shown on the display.

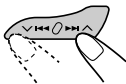

- Select "DEMO OFF."



DEMO OFF ↔ DEMO ON



- Finish the setting.



To activate the display demonstration, repeat the same procedure and select "DEMO ON" in step 3.



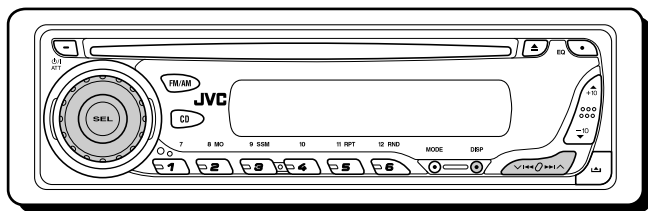

## Setting the clock

**1** Press and hold SEL (select) for more than 2 seconds so that one of the PSM items appears on the display. (PSM: see page 24.)



**2** Set the hour.

- 1 Select "CLOCK H" (hour) if not shown on the display.
- 2 Adjust the hour.

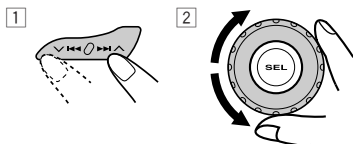

**3** Set the minute.

- 1 Select "CLOCK M" (minute).
- 2 Adjust the minute.

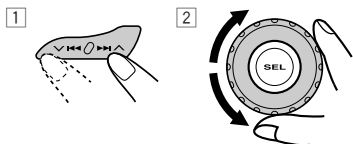

**4** Finish the setting.



To check the current clock time or change the display mode



Press DISP (display) repeatedly. Each time you press the button, the display changes as follows:

- During tuner operation:

Frequency ↔ Clock

- During disc operation:

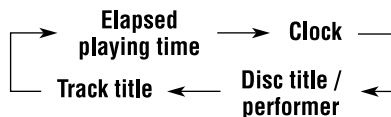

**Notes:**

- While playing an audio CD, "NO NAME" appears for the disc title/performer and the track title.
- For indication change while playing a CD Text or an MP3 disc, see also pages 17 and 19.

- During power off:

The power turns on and the clock time is shown for 5 seconds, then the power turns off.



# RADIO OPERATIONS

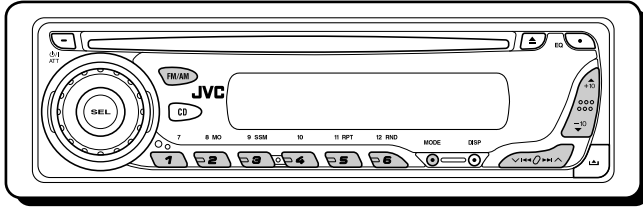

## Listening to the radio

You can use either automatic searching or manual searching to tune in to a particular station.

### Searching for a station automatically: Auto search

#### 1 Select the band (FM1 – 3, AM).



Each time you press the button, the band changes as follows:

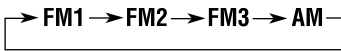

Lights up when receiving an FM stereo broadcast with sufficient signal strength.

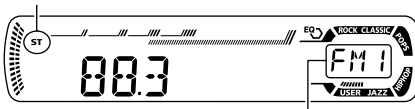

Selected band appears.

#### Note:

This receiver has three FM bands (FM1, FM2, FM3). You can use any one of them to listen to an FM broadcast.

#### 2 Start searching for a station.

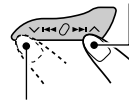

To search for stations of higher frequencies

To search for stations of lower frequencies

When a station is received, searching stops.

To stop searching before a station is received, press the same button you have pressed for searching.

## Searching for a station manually: Manual search

### 1 Select the band (FM1 – 3, AM).



Each time you press the button, the band changes as follows:

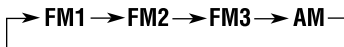

#### Note:

This receiver has three FM bands (FM1, FM2, FM3). You can use any one of them to listen to an FM broadcast.

### 2 Press and hold until “M” (manual) starts flashing on the display.

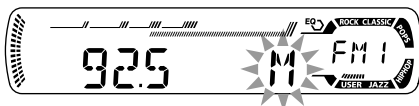

### 3 Tune in to a station you want while “M” (manual) is still flashing.

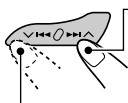

To tune in to stations of higher frequencies

To tune in to stations of lower frequencies

- If you release your finger from the button, the manual mode will automatically turn off after 5 seconds.
- If you hold down the button, the frequency keeps changing (in 50 kHz intervals for FM and 9 kHz for AM) until you release the button.

## When an FM stereo broadcast is hard to receive:

MODE



- 1 Press MODE to enter the functions mode while listening to an FM stereo broadcast.

MO



- 2 Press MO (monaural), while “MODE” is still flashing on the display, so that “MONO” appears on the display. Each time you press the button, monaural mode turns on and off alternately.

MO (monaural) indicator



When the MO indicator is lit on the display, the sound you hear becomes monaural but the reception will be improved.



## Storing stations in memory

You can use one of the following two methods to store broadcasting stations in memory.

- Automatic preset of FM stations: SSM (Strong-station Sequential Memory)
- Manual preset of both FM and AM stations

### FM station automatic preset: SSM

You can preset 6 local FM stations in each FM band (FM1, FM2, and FM3).

#### 1 Select the FM band (FM1 – 3) you want to store FM stations into.



Each time you press the button, the band changes as follows:

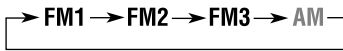

#### 2 Press MODE to enter the functions mode.

MODE



#### 3 Press and hold SSM for about 2 seconds.

9 SSM



“SSM” flashes, then disappears when automatic presetting is over.

Local FM stations with the strongest signals are searched and stored automatically in the band number you have selected (FM1, FM2, or FM3). These stations are preset in the number buttons—No.1 (lowest frequency) to No.6 (highest frequency).

When automatic preset is over, the station stored in number button 1 will be automatically tuned in.

### Manual preset

You can preset up to 6 stations in each band (FM1, FM2, FM3, and AM) manually.

Ex.: Storing FM station of 92.5 MHz into the preset number 1 of the FM1 band.

#### 1 Select the band (FM1 – 3, AM) you want to store stations into (in this example, FM1).



Each time you press the button, the band changes as follows:

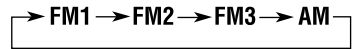

#### 2 Tune in to a station (in this example, of 92.5 MHz).

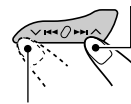

To tune in to stations of higher frequencies

To tune in to stations of lower frequencies

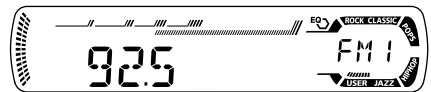

- 3** Press and hold the number button (in this example, 1) for more than 2 seconds.

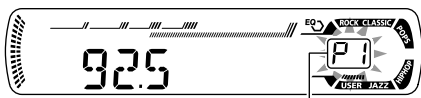

Preset number flashes for a while.

- 4** Repeat the above procedure to store other stations into other preset numbers.

**Notes:**

- A previously preset station is erased when a new station is stored in the same preset number.
- Preset stations are erased when the power supply to the memory circuit is interrupted (for example, during battery replacement). If this occurs, preset the stations again.

## Tuning in to a preset station

You can easily tune in to a preset station. Remember that you must store stations first. If you have not stored them yet, see “Storing stations in memory” on pages 12 and 13.

- 1** Select the band (FM1 – 3, AM).



Each time you press the button, the band changes as follows:

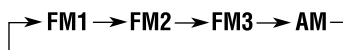

- 2** Select the number (1 – 6) for the preset station you want.

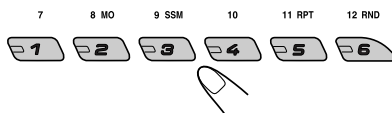

**Note:**

You can also use the ▲ (up) or ▼ (down) button on the unit to select the next or previous preset stations. Each time you press the ▲ (up) or ▼ (down) button, the next or previous preset station is tuned in.



# CD OPERATIONS

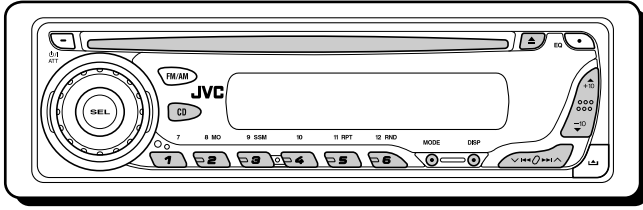

Refer “MP3 OPERATIONS” on pages 18 to 21 for operating MP3 discs.

## Playing a CD

### Insert a CD into the loading slot.

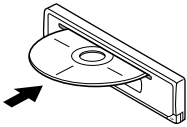

The unit turns on, draws the CD and starts playback automatically.

#### Note on One-Touch Operation:

When a CD is already in the loading slot, pressing CD turns on the unit and starts playback automatically.

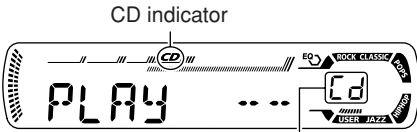

Current source indication

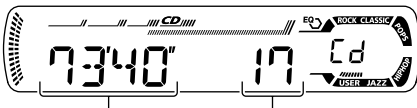

Total playing time of the inserted disc      Total track number of the inserted disc

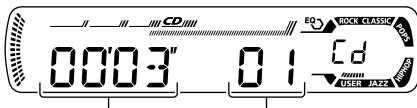

Elapsed playing time      Current track number

All tracks will be played repeatedly until you stop playback.

#### Notes:

- When a CD is inserted upside down, “EJECT” appears on the display and the CD automatically ejects.
- If there is no CD in the loading slot, you cannot select CD as the source. “NO DISC” appears on the display.
- If the current disc is a CD Text, disc title/performer and then track title will automatically appear.

### To stop play and eject the CD

Press ▲.

CD play stops and the CD automatically ejects from the loading slot. The source changes to the previously selected source.

- If you change the source, CD play also stops (without ejecting the CD).

Next time you select “CD” as the source, CD play starts from where playback has been stopped previously.

#### Notes:

- If the ejected disc is not removed for about 15 seconds, the disc is automatically inserted again into the loading slot to protect it from dust. (Disc play will not start this time.)
- You can eject the disc even when the unit is turned off.



# Locating a track or a particular portion on a CD

## To fast-forward or reverse the track

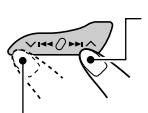

Press and hold **▶▶** **◀**, while playing a CD, to fast-forward the track.

Press and hold **◀◀** **▶**, while playing a CD, to reverse the track.

## To go to the next or previous tracks

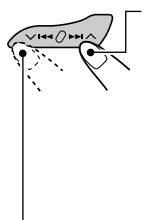

Press **▶▶** **▲** briefly, while playing a CD, to go ahead to the beginning of the next track. Each time you press the button consecutively, the beginning of the next tracks is located and played back.

Press **◀◀** **▼** briefly, while playing a CD, to go back to the beginning of the current track. Each time you press the button consecutively, the beginning of the previous tracks is located and played back.

## To go to a particular track directly

Press the number button corresponding to the track number to start its playback.

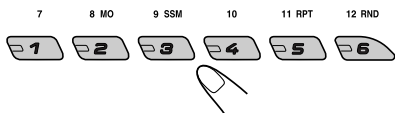

- To select a track number from 01 – 06: Press 1 (7) – 6 (12) briefly.
- To select a track number from 07 – 12: Press and hold 1 (7) – 6 (12) for more than one second.

## To go to a track quickly (+10 and -10 buttons)

- 1 Press MODE to enter the functions mode while playing a CD.



- 2 Press +10 or -10.

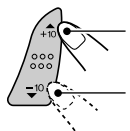

To skip 10 tracks\* forwards to the last track

To skip 10 tracks\* backwards to the first track

\* First time you press +10 or -10 button, the track skips to the nearest higher or lower track with a track number of multiple ten (ex. 10th, 20th, 30th).

Then each time you press the button, you can skip 10 tracks (see "How to use the +10 and -10 buttons" below).

- After the last track, the first track will be selected, and vice versa.

### How to use the +10 and -10 buttons

- Ex. 1: To select track number 32 while playing track number 6

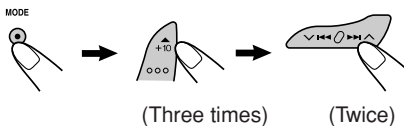

Track 6 → 10 → 20 → 30 → 31 → 32

- Ex. 2: To select track number 8 while playing track number 36

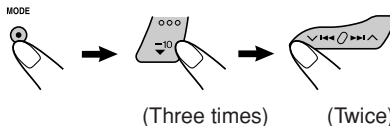

Track 36 → 30 → 20 → 10 → 9 → 8



# Selecting CD playback modes

## To play back tracks at random (Disc Random Play)

You can play back all tracks on the CD at random.

MODE



- 1 Press MODE to enter the functions mode while playing a CD.

12 RND



- 2 Press RND (random), while "MODE" is still flashing on the display, so that "DISC RND" appears on the display. Each time you press the button, disc random play mode turns on and off alternately.

RND and indicators

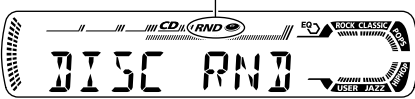

When disc random play is turned on, the RND and indicators light up on the display. A track randomly selected starts playing.

## To play back tracks repeatedly (Track Repeat Play)

You can play back the current track repeatedly.

MODE



- 1 Press MODE to enter the functions mode while playing a CD.

11 RPT



- 2 Press RPT (repeat), while "MODE" is still flashing on the display, so that "TRK RPT" appears on the display. Each time you press the button, track repeat play mode turns on and off alternately.

RPT indicator

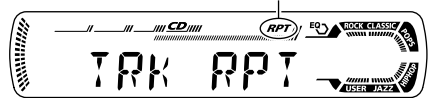

When track repeat play is turned on, the RPT indicator lights up on the display. The current track starts playing repeatedly.





## Playing a CD Text

In a CD Text, some information about the disc (its disc title, performer, and track title) is recorded. This CD Text information will be shown automatically when you play a CD Text.

**To change the CD Text information manually, select text display mode while playing a CD Text.**

DISP



Press DISP (display) repeatedly. Each time you press the button, the display changes as follows:

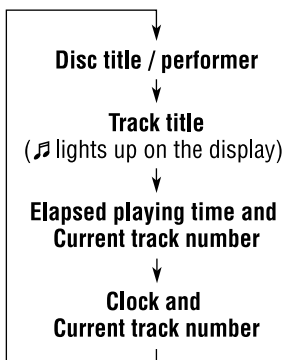

### Notes:

- The display shows up to 8 characters at one time and scrolls if there are more than 8 characters. See also “To select the scroll mode—SCROLL” on page 25. Some characters or symbols will not be shown (and be blanked) on the display. (Ex. “ABC&!d#” ⇔ “ABCA D ”)
- When you press DISP (display) while playing an audio CD, “NO NAME” appears for the disc title/performer and the track title.
- When track title is shown, the Tr indicator and current track number also appear on the right side of the display.

## Prohibiting disc ejection

You can prohibit disc ejection and can lock a disc in the loading slot.

**While pressing CD, press and hold ▲ for more than 2 seconds.**



“EJECT” flashes on the display for about 5 seconds, and the disc is locked and cannot be ejected.



**To cancel the prohibition and unlock the disc**

While pressing CD, press and hold ▲ again for more than 2 seconds.

“EJECT” appears on the display, and the disc ejects from the loading slot.

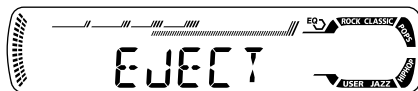

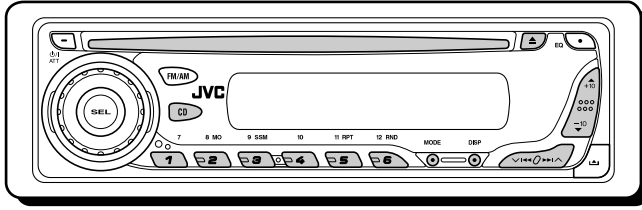

Refer also to “CD OPERATIONS” on pages 14 to 17.

## Playing an MP3 disc

Insert an MP3 disc into the loading slot.

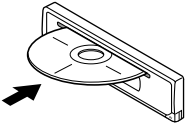

### Note on One-Touch operation:

When a disc is already in the loading slot, pressing CD turns on the unit and starts playback automatically.

### Notes:

- MP3 discs require a longer readout time. (It differs due to the complexity of the folder/file configuration.)
- When playback starts, folder and file names (or ID3 tags) will automatically appear. (See also page 19.)
- If you change the source or turn the power off, disc playback stops (without ejecting the disc). Next time you select the CD player as the source or turn the power on, disc play starts from where playback has been stopped previously.

### To stop play and eject the disc

Press **▲**.

Playback stops and the disc automatically ejects from the loading slot.

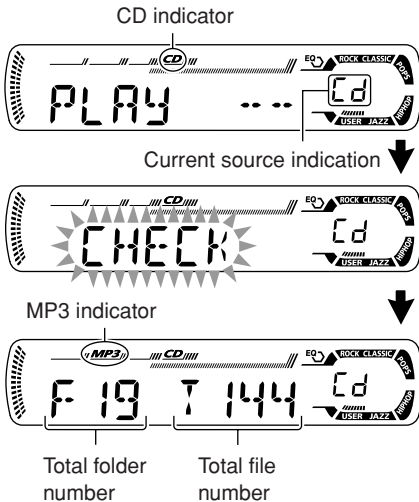

Ex.: When the disc contains 19 folders and 144 MP3 files

All files will be played repeatedly until you stop playback.



## To change the display information

While playing back an MP3 file, you can change the MP3 disc information shown on the display.



Press DISP (display) repeatedly. Each time you press the button, the display changes to show the following:

- When “TAG DISP” is set to “TAG ON” (initial setting: see page 25)

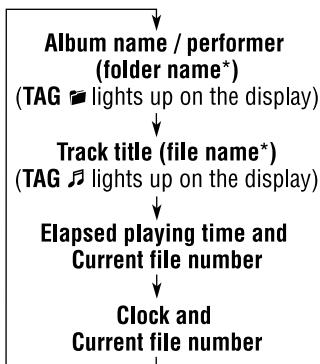

\* If an MP3 file does not have ID3 tags, folder name and file name appear. In this case, the TAG indicator will not light up on the display.

- When “TAG DISP” is set to “TAG OFF”

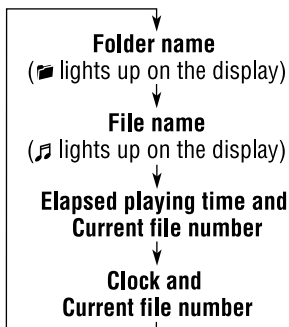

### Notes:

- The display shows up to 8 characters at a time and scrolls if there are more than 8 characters. See also “To select the scroll mode—SCROLL” on page 25.
- When folder or file name is shown, current folder number or the Tr indicator and current file number also appear on the right side of the display.

## Locating a file or a particular portion on an MP3 disc

### To fast-forward or reverse the file

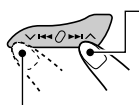

Press and hold ►►▲ while playing an MP3 disc, to fast-forward the file.

Press and hold ▼◄◄ while playing an MP3 disc, to reverse the file.

### Note:

During this operation, you can only hear intermittent sounds. (The elapsed playing time also changes intermittently on the display.)

### To skip to the next or previous files

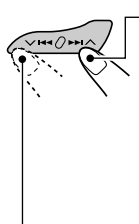

Press ►►▲ briefly while playing, to skip ahead to the beginning of the next file. Each time you press the button consecutively, the beginning of the next files is located and played back.

Press ▼◄◄ briefly, while playing, to skip back to the beginning of the current file. Each time you press the button consecutively, the beginning of the previous files is located and played back.

### To go to a particular file quickly within the current folder (+10 and -10 buttons)

- 1 Press MODE to enter the functions mode while playing an MP3 disc.



- 2 Press +10 or -10.

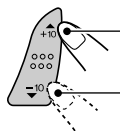

To skip 10 files\* forwards to the last file

To skip 10 files\* backwards to the first file

CONTINUED ON THE NEXT PAGE

\* First time you press +10 or -10 button, the file skips to the nearest higher or lower file with a file number of multiple ten (ex. 10th, 20th, 30th).

Then each time you press the button, you can skip 10 files (see "How to use the +10 and -10 buttons" below).

- After the last file, the first file will be selected, and vice versa.

**How to use the +10 and -10 buttons**

- Ex. 1: To select file number 32 while playing file number 6

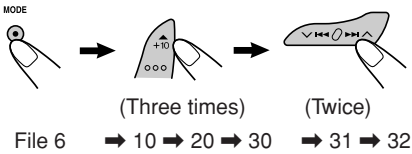

- Ex. 2: To select file number 8 while playing file number 36

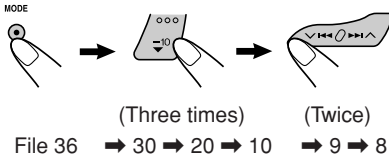

**To go to a particular folder directly**

**IMPORTANT:**

To directly select the folders using the number button(s), it is required that folders are assigned 2 digit numbers at the beginning of their folder names. (This can only be done during the recording of CD-Rs or CD-RWs.)

Ex.: If folder name is "01 ABC"

- Press 1 to go to Folder 01 ABC.
- If folder name is "1 ABC," pressing 1 does not work.

If folder name is "12 ABC"

- Press and hold 6 (12) to go to Folder 12 ABC.

Press the number button corresponding to the folder number to start playing the first file in the selected folder.

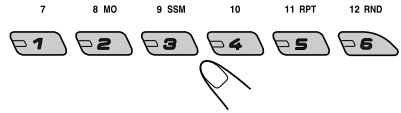

- To select a folder number from 01 – 06: Press 1 (7) – 6 (12) briefly.
- To select a folder number from 07 – 12: Press and hold 1 (7) – 6 (12) for more than one second.

**Notes:**

- If indicator flashes on the display after you have selected a folder, it means that the folder does not contain any MP3 files.
- You cannot directly select a folder with a number greater than 12.

**To select a particular file in a folder,** press

or after selecting the folder.

**To skip to the next or previous folder**

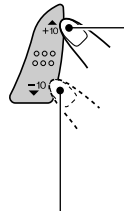

Press (up) while playing an MP3 disc to skip to the next folder.

Each time you press the button consecutively, the next folder is located (and the first file in the folder starts playing, if recorded).

Press (down) while playing an MP3 disc to skip back to the previous folder.

Each time you press the button consecutively, the previous folder is located (and the first file in the folder starts playing, if recorded).

**Note:**

If the folder does not contain any MP3 files, it is skipped.



## Selecting MP3 playback modes

### To play back files at random (Folder Random/Disc Random Play)

You can play back all files of the current folder or all files on the MP3 disc at random.

MODE



- 1 Press MODE to enter the functions mode while playing an MP3 disc.

12 RND



- 2 Press RND (random), while "MODE" is still flashing on the display, so that "FLDR RND" or "DISC RND" appears on the display. Each time you press the button, the random play mode changes as follows:



RND and (folder) indicators

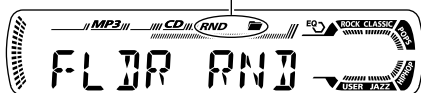

Ex.: When you select "FLDR RND"

Mode	Active indicator	Plays at random
FLDR RND	RND and  indicators light up.	All files of the current folder, then files of the next folder and so on.
DISC RND	RND and  indicators light up.	All files on the disc.

### To play back files repeatedly (Track Repeat/Folder Repeat Play)

You can play back the current file or all the files in the current folder repeatedly.

MODE



- 1 Press MODE to enter the functions mode while playing an MP3 disc.

11 RPT



- 2 Press RPT (repeat), while "MODE" is still flashing on the display, so that "TRK RPT" or "FLDR RPT" appears on the display. Each time you press the button, the repeat play mode changes as follows:

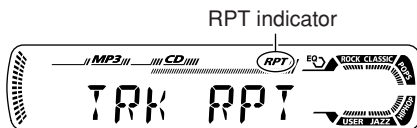

Ex.: When you select "TRK RPT"

Mode	Active indicator	Plays repeatedly
TRK RPT	RPT indicator lights up.	The current (or specified) file.
FLDR RPT	and RPT indicators light up.	All files of the current (or specified) folder.



# SOUND ADJUSTMENTS

## Selecting preset sound modes (C-EQ: custom equalizer)

You can select a preset sound mode (C-EQ: custom equalizer) suitable to the music genre.

### Select the sound mode you want.



Each time you press the button, the sound modes change as follows:

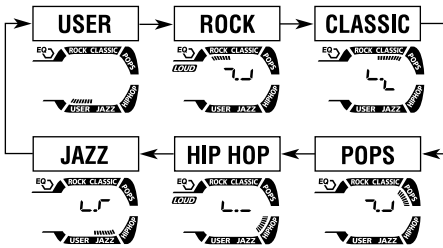

Indication pattern changes for each sound mode except for "USER."



Ex.: When you select "ROCK"

Indication	For:	Preset values		
		BAS	TRE	LOUD
USER	(Flat sound)	00	00	OFF
ROCK	Rock or disco music	+03	+01	ON
CLASSIC	Classical music	+01	-02	OFF
POPS	Light music	+04	+01	OFF
HIP HOP	Funk or rap music	+02	00	ON
JAZZ	Jazz music	+02	+03	OFF

### Note:

You can adjust each sound mode to your preference. Once you make an adjustment, it is automatically stored for the currently selected sound mode. See "Adjusting the sound" on page 23.



## Adjusting the sound

You can adjust the sound characteristics to your preference.

### 1 Select the item you want to adjust.



Each time you press the button, the adjustable items change as follows:

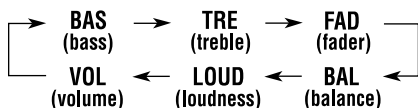

Indication	To do:	Range
BAS* <sup>1</sup>	Adjust the bass.	-06 (min.)   +06 (max.)
TRE* <sup>1</sup>	Adjust the treble.	-06 (min.)   +06 (max.)
FAD* <sup>2</sup>	Adjust the front and rear speaker balance.	R06 (Rear only)   F06 (Front only)
BAL	Adjust the left and right speaker balance.	L06 (Left only)   R06 (Right only)
LOUD* <sup>1</sup>	Boost low and high frequencies to produce a well-balanced sound at low volume level.	LOUD ON   LOUD OFF
VOL* <sup>3</sup>	Adjust the volume.	00 (min.)   30 or 50 (max.)* <sup>4</sup>

\*<sup>1</sup> When you adjust the bass, treble, or loudness, the adjustment you have made is stored for the currently selected sound mode (C-EQ) including "USER."

\*<sup>2</sup> If you are using a two-speaker system, set the fader level to "00."

\*<sup>3</sup> Normally the control dial works as the volume control. So you do not have to select "VOL" to adjust the volume level.

\*<sup>4</sup> Depending on the amplifier gain control setting. (See page 25 for details.)

### 2 Adjust the setting.

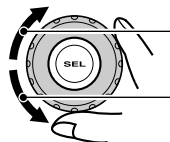

To increase the level or turn on the loudness

To decrease the level or turn off the loudness

Indication pattern changes as you adjust the bass or treble.

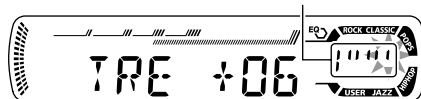

Ex. 1: When you adjust "TRE" (treble)

LOUD indicator

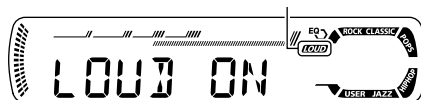

Ex. 2: When you turn on the loudness

### 3 Repeat steps 1 and 2 to adjust the other items.

To reset each sound mode to the factory settings, repeat the same procedure and reassign the preset values listed in the table on page 22.



# OTHER MAIN FUNCTIONS

## Changing the general settings (PSM)

You can change the items listed in the table below by using the PSM (Preferred Setting Mode) control.

### Basic Procedure

**1** Press and hold SEL (select) for more than 2 seconds so that one of the PSM items appears on the display. (See below.)



**2** Select the PSM item you want to adjust.

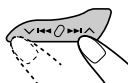

**3** Adjust the PSM item selected.



**4** Repeat steps 2 and 3 to adjust the other PSM items if necessary.

**5** Finish the setting.



### Preferred Setting Mode (PSM) items

• For detailed operations of each PSM items, refer to the pages listed in the table.

	Indications	Selectable values/items		Factory-preset settings	See page
<b>DEMO</b>	Display demonstration	DEMO OFF	DEMO ON	DEMO ON	8
<b>CLOCK H</b>	Hour adjustment	1 – 12		1 (1:00)	9
<b>CLOCK M</b>	Minute adjustment	00 – 59		00 (1:00)	
<b>DIMMER</b>	Dimmer mode	OFF	ON	OFF	25
<b>SCROLL</b>	Scroll mode	ONCE ↶	↔ OFF	AUTO ↷	ONCE 25
<b>TAG DISP</b>	Tag display	TAG OFF	TAG ON	TAG ON	25
<b>AMP GAIN</b>	Amplifier gain control	LOW PWR	HIGH PWR	HIGH PWR	25





## To select the dimmer mode—DIMMER

You can dim the display at night (according to your preference).

When shipped from the factory, dimmer is deactivated.

- OFF: Cancels the dimmer.
- ON: Activates the dimmer.

## To select the scroll mode—SCROLL

You can select the scroll mode for the disc information (when the entire text cannot be shown at once).

When shipped from the factory, scroll mode is set to "ONCE."

- ONCE: Scrolls only once.
- AUTO: Repeats the scroll (5-second intervals in between).
- OFF: Cancels scroll mode.

### **Note:**

*Even if the scroll mode is set to "OFF," you can scroll the display by pressing DISP (display) for more than one second.*

## To turn the tag display on or off—TAG DISP

An MP3 file can contain file information called "ID3 Tag" where its album name, performer, track title, etc. are recorded.

There are two versions—ID3v1 (ID3 Tag version 1) and ID3v2 (ID3 Tag version 2). If both ID3v1 and ID3v2 are recorded on a disc, ID3v2 information will be shown.

When shipped from the factory, "TAG ON" is selected.

- TAG OFF: Turns off the ID3 tag display while playing MP3 files. (Only the folder name and file name can be shown.)
- TAG ON: Turns on the ID3 tag display while playing MP3 files.
  - If an MP3 file does not have ID3 tags, folder name and file name appear.

## To select the amplifier gain control—AMP GAIN

You can change the maximum volume level of this unit. When the maximum power of the speakers is less than 50 W, select "LOW PWR" to prevent them from being damaged.

When shipped from the factory, "HIGH PWR" is selected.

- LOW PWR: You can adjust the volume level from "VOL 00" to "VOL 30."

### **Note:**

*If you change the setting from "HIGH PWR" to "LOW PWR" while listening at a volume level more than 30, the unit automatically changes the volume level to "VOL 30."*

- HIGH PWR: You can adjust the volume level from "VOL 00" to "VOL 50."



## Detaching the control panel

You can detach the control panel when leaving the car.

When detaching or attaching the control panel, be careful not to damage the connectors on the back of the control panel and on the panel holder.

### Detaching the control panel

Before detaching the control panel, be sure to turn off the power.

#### 1 Unlock the control panel.

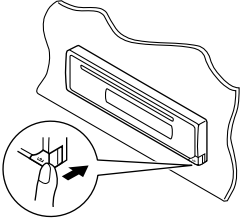

#### 2 Lift and pull the control panel out of the unit.

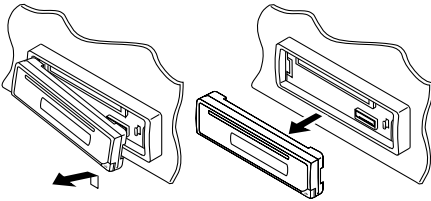

#### 3 Put the detached control panel into the provided case.

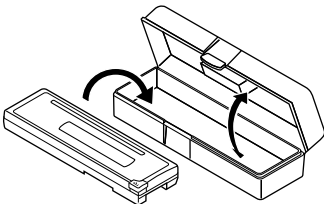

## Attaching the control panel

#### 1 Insert the left side of the control panel into the groove on the panel holder.

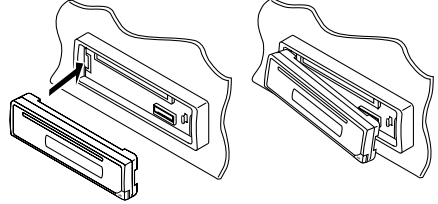

#### 2 Press the right side of the control panel to fix it to the panel holder.

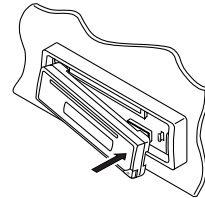



## Playing a CD-R or CD-RW

- Use only “finalized” CD-Rs or CD-RWs.
- This unit can play back only the files of the same type which is first detected if a disc includes both audio CD (CD-DA) files and MP3 files.
- This unit can play back multi-session discs; however, unclosed sessions will be skipped while playing.
- Some CD-Rs or CD-RWs may not play back on this unit because of their disc characteristics, and for the following causes:
  - Discs are dirty or scratched.
  - Moisture condensation on the lens inside the unit.
  - The pickup lens inside the unit is dirty.
  - CD-R/CD-RW on which the files are written with “Packet Write” method.
  - There are improper recording conditions (missing data, etc.) or media conditions (stain, scratch, warp, etc.).
- CD-RWs may require a longer readout time since the reflectance of CD-RWs is lower than that of regular CDs.
- Do not use following CD-Rs or CD-RWs:
  - Discs with stickers, labels, or protective seal stuck to the surface.
  - Discs on which labels can be directly printed by an ink jet printer.

Using these discs under high temperatures or high humidity may cause malfunctions or damage to discs.

## Playing an MP3 disc

- This unit can play back MP3 files with the extension code <.mp3> (regardless of the letter case—upper/lower).
- This unit can show the names of albums, artists (performer), and ID3 Tag (Version 1.0, 1.1, 2.2, 2.3, or 2.4) for MP3 files.
- This unit can handle only one-byte characters. No other characters can be correctly displayed.
- This unit can play back MP3 files meeting the conditions below:
  - Bit rate: 8 kbps — 320 kbps
  - Sampling frequency: 48 kHz, 44.1 kHz, 32 kHz (for MPEG-1) 24 kHz, 22.05 kHz, 16 kHz (for MPEG-2)
  - Disc format: ISO 9660 Level 1/Level 2, Romeo, Joliet, Windows long file name
- The maximum number of characters for file/folder names vary among the disc format used (includes 4 extension characters—<.mp3>).
  - ISO 9660 Level 1: up to 12 characters
  - ISO 9660 Level 2: up to 31 characters
  - Romeo\*: up to 128 (72) characters
  - Joliet\*: up to 64 (36) characters
  - Windows long file name\*: up to 128 (72) characters

*\* The parenthetic figure is the maximum number of characters for file/folder names in case the total number of files and folders is 313 or more.*
- This unit can recognize the total of 512 files, of 200 folder, and of 8 hierarchies.
- This unit can play back the files recorded in VBR (variable bit rate).
 

The files recorded in VBR have a discrepancy in elapsed time display, and do not show the actual elapsed time. Especially, after performing the search function, this difference becomes noticeable.
- This unit cannot play back the following files:
  - MP3 files encoded with MP3i and MP3 PRO formats.
  - MP3 files encoded in an unappropriated format.
  - MP3 files encoded with Layer 1/2.
  - Files which have the data such as WMA, WAVE, ATRAC3, etc.
- The search function works but search speed is not constant.



# TROUBLESHOOTING

What appears to be trouble is not always serious. Check the following points before calling a service center.

	Symptoms	Causes	Remedies
General	<ul style="list-style-type: none"> <li>Sound cannot be heard from the speakers.</li> </ul>	The volume level is set to the minimum level.	Adjust it to the optimum level.
		Connections are incorrect.	Check the cords and connections.
	<ul style="list-style-type: none"> <li>This unit does not work at all.</li> </ul>	The built-in microcomputer may have functioned incorrectly due to noise, etc.	While holding SEL (select), press <b>⏻/I ATT</b> (standby/on attenuator) for more than 2 seconds to reset the unit. (Your preset adjustment will also be erased.) (See page 2.)
FM/AM	<ul style="list-style-type: none"> <li>SSM (Strong-station Sequential Memory) automatic preset does not work.</li> </ul>	Signals are too weak.	Store stations manually.
	<ul style="list-style-type: none"> <li>Static noise while listening to the radio.</li> </ul>	The antenna is not connected firmly.	Connect the antenna firmly.
Disc Playback	<ul style="list-style-type: none"> <li>Disc automatically ejects.</li> </ul>	Disc is inserted upside down.	Insert the disc correctly.
	<ul style="list-style-type: none"> <li>CD-R/CD-RW cannot be played back.</li> <li>Tracks on the CD-R/CD-RW cannot be skipped.</li> </ul>	CD-R/CD-RW is not finalized.	<ul style="list-style-type: none"> <li>Insert a finalized CD-R/CD-RW.</li> <li>Finalize the CD-R/CD-RW with the component which you used for recording.</li> </ul>
		<ul style="list-style-type: none"> <li>Disc can be neither played back nor ejected.</li> </ul>	Disc is locked.
	The CD player may have functioned incorrectly.		While holding <b>⏻/I ATT</b> (standby/on attenuator), press <b>▲</b> (eject) for more than 2 seconds. Be careful not to drop the disc when it ejects.
	<ul style="list-style-type: none"> <li>Disc sound is sometimes interrupted.</li> </ul>	You are driving on rough roads.	Stop playback while driving on rough roads.
		Disc is scratched.	Change the disc.
		Connections are incorrect.	Check the cords and connections.
	<ul style="list-style-type: none"> <li>"NO DISC" appears on the display.</li> </ul>	No disc in the loading slot.	Insert a disc into the loading slot.
Disc is inserted incorrectly.		Insert the disc correctly.	



Symptoms	Causes	Remedies
<ul style="list-style-type: none"> <li>Disc cannot be played back.</li> </ul>	No MP3 files are recorded on the disc.	Change the disc.
	MP3 files do not have the extension code <.mp3> in their file names.	Add the extension code <.mp3> to their file names.
	MP3 files are not recorded in the format compliant with ISO 9660 Level 1, Level 2, Romeo, or Joliet.	Change the disc. (Record MP3 files using a compliant application.)
<ul style="list-style-type: none"> <li>Noise is generated.</li> </ul>	The file played back is not an MP3 file (although it has the extension code <.mp3>).	Skip to another file or change the disc. (Do not add the extension code <.mp3> to non-MP3 files.)
<ul style="list-style-type: none"> <li>A longer readout time is required ("CHECK" keeps flashing on the display).</li> </ul>	Readout time varies due to the complexity of the folder/file configuration.	Do not use too many hierarchies and folders. Also, do not record any other types of audio tracks together with MP3 files.
<ul style="list-style-type: none"> <li>Files cannot be played back as you have intended them to play.</li> </ul>	Playback order is determined when the files are recorded.	_____
<ul style="list-style-type: none"> <li>Elapsed playing time is not correct.</li> </ul>	This sometimes occurs during play. This is caused by how the files are recorded on the disc.	_____
<ul style="list-style-type: none"> <li> indicator flashes on the display.</li> </ul>	The current folder does not contain any MP3 file.	Select another folder.
<ul style="list-style-type: none"> <li>"NO FILES" appears on the display.</li> </ul>	The current disc does not contain any MP3 file.	Insert a disc that contains MP3 files.
<ul style="list-style-type: none"> <li>Correct characters are not displayed (e.g. album name).</li> </ul>	This unit can only display alphabets (capital: A–Z), numbers, and a limited number of symbols.	_____

MP3 Playback

**About mistracking:**

Mistracking may result from driving on extremely rough roads. This does not damage the unit and the disc, but will be annoying.

We recommend that you stop disc play while driving on such rough roads.



# MAINTENANCE

## How to clean the connectors

Frequent detachment will deteriorate the connectors.

To minimize this possibility, periodically wipe the connectors with a cotton swab or cloth moistened with alcohol, being careful not to damage the connectors.

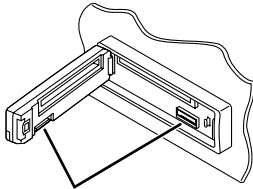

Connector

## Moisture condensation

Moisture may condense on the lens inside the CD player in the following cases:

- After starting the heater in the car.
- If it becomes very humid inside the car.

Should this occur, the CD player may malfunction. In this case, eject the disc and leave the unit turned on for a few hours until the moisture evaporates.

## How to handle discs

**When removing a disc from its case**, press down the center holder of the case and lift the disc out, holding it by the edges.

Center holder



- Always hold the disc by the edges. Do not touch its recording surface.

**When storing a disc into its case**, gently insert the disc around the center holder (with the printed surface facing up).

- Make sure to store discs into the cases after use.

## To keep discs clean

A dirty disc may not be played correctly. If a disc does become dirty, wipe it with a soft cloth in a straight line from center to edge.



## To play new discs

New discs may have some rough spots around the inner and outer edges. If such a disc is used, this unit may reject the disc.



To remove these rough spots, rub the edges with a pencil or ball-point pen, etc.

### CAUTIONS:

*Do not insert the following discs into the loading slot:*

- 8 cm discs (single CD)
- Unusual shape—heart, flower, etc.

### Do not use the following discs:

Warped disc



Sticker



Sticker residue

Disc



Stick-on label

## AUDIO AMPLIFIER SECTION

Maximum Power Output:

Front: 50 W per channel

Rear: 50 W per channel

Continuous Power Output (RMS):

Front: 19 W per channel into 4  $\Omega$ , 40 Hz to 20 000 Hz at no more than 0.8% total harmonic distortion.

Rear: 19 W per channel into 4  $\Omega$ , 40 Hz to 20 000 Hz at no more than 0.8% total harmonic distortion.

Load Impedance: 4  $\Omega$  (4  $\Omega$  to 8  $\Omega$  allowance)

Tone Control Range:

Bass:  $\pm 10$  dB at 100 Hz

Treble:  $\pm 10$  dB at 10 kHz

Frequency Response: 40 Hz to 20 000 Hz

Signal-to-Noise Ratio: 70 dB

Line-Out Level/Impedance:

2.0 V/20 k $\Omega$  load (full scale)

Output Impedance: 1 k $\Omega$

## TUNER SECTION

Frequency Range:

FM: 87.5 MHz to 108.0 MHz

AM: 531 kHz to 1 602 kHz

### **[FM Tuner]**

Usable Sensitivity: 11.3 dBf (1.0  $\mu$ V/75  $\Omega$ )

50 dB Quieting Sensitivity:

16.3 dBf (1.8  $\mu$ V/75  $\Omega$ )

Alternate Channel Selectivity (400 kHz):

65 dB

Frequency Response: 40 Hz to 15 000 Hz

Stereo Separation: 35 dB

Capture Ratio: 1.5 dB

### **[AM Tuner]**

Sensitivity: 20  $\mu$ V

Selectivity: 35 dB

## CD PLAYER SECTION

Type: Compact disc player

Signal Detection System: Non-contact optical pickup (semiconductor laser)

Number of channels: 2 channels (stereo)

Frequency Response: 5 Hz to 20 000 Hz

Dynamic Range: 96 dB

Signal-to-Noise Ratio: 98 dB

Wow and Flutter: Less than measurable limit

MP3 decoding format:

MPEG 1/2 Audio Layer 3

Max. Bit Rate: 320 Kbps

## GENERAL

Power Requirement:

Operating Voltage:

DC 14.4 V (11 V to 16 V allowance)

Grounding System: Negative ground

Allowable Operating Temperature:

0°C to +40°C

Dimensions (W  $\times$  H  $\times$  D):

Installation Size (approx.):

182 mm  $\times$  52 mm  $\times$  150 mm

Panel Size (approx.):

188 mm  $\times$  58 mm  $\times$  11 mm

Mass (approx.):

1.4 kg (excluding accessories)

*Design and specifications are subject to change without notice.*

**Having TROUBLE with operation?  
Please reset your unit  
Refer to page of How to reset your unit**



# JVC



EN, TH

© 2004 Victor Company of Japan, Limited

1004DTSMDTJEIN



### ENGLISH

This unit is designed to operate on **12 V DC, NEGATIVE ground electrical systems**. If your vehicle does not have this system, a voltage inverter is required, which can be purchased at JVC car audio dealers.

#### Parts list for installation and connection

The following parts are provided for this unit.  
After checking them, please set them correctly.

**A / B**  
Hard case/Control panel  
ถังบรรจุ/หน้าปัด

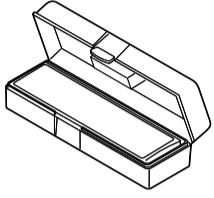

**C**  
Sleeve  
ปลอกหุ้ม

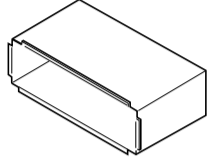

**D**  
Trim plate  
แผ่นโลหะขอบแดง

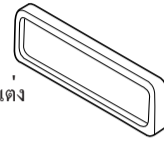

**E**  
Power cord  
สายเคเบิลกำลัง

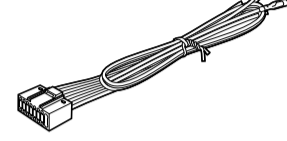

**F**  
Washer (ø5)  
ประเก็นวงแหวน (ø5)



**G**  
Lock nut (M5)  
นอตล็อก (M5)



**H**  
Mounting bolt (M5 x 20 mm)  
สลักติด (M5 x 20 มิลลิเมตร)



**I**  
Rubber cushion  
ยางกันกระแทก



**J**  
Handles  
คันบังคับ



**K**  
Remote controller  
รีโมตคอนโทรล



**L**  
Battery  
แบตเตอรี่

**CR2025**

### ไทย

ชุดประกอบนี้ได้รับการออกแบบมาเพื่อใช้งานกับระบบกระแสไฟฟ้าสายดินขั้วลบกระแสตรง **12 โวลท์** หากรถยนต์ของคุณไม่ได้ใช้ระบบนี้ ต้องใช้เครื่องแปลงกระแสไฟช่วย ซึ่งสามารถหาซื้อได้จากร้านขายเครื่องเสียงรถยนต์ JVC

#### รายการส่วนประกอบสำหรับติดตั้งและเชื่อมต่อกัน

ส่วนประกอบต่อไปนี้ใหม่กับชุดประกอบนี้ หลังจากตรวจสอบแล้ว ปรับตั้งเครื่องให้ถูกต้อง

## INSTALLATION (IN-DASH MOUNTING)

The following illustration shows a typical installation. If you have any questions or require information regarding installation kits, consult your JVC car audio dealer or a company supplying kits.

• If you are not sure how to install this unit correctly, have it installed by a qualified technician.

## การติดตั้ง (การประกอบแผงหน้าปัด)

ภาพตัวอย่างต่อไปนี้แสดงถึงการติดตั้งแบบทั่วไป หากคุณมีปัญหาหรือต้องการข้อมูลเพิ่มเติมเกี่ยวกับชุดติดตั้ง กรุณาปรึกษากับผู้ขายเครื่องเสียงรถยนต์ JVC ของท่านหรือบริษัท

• ชุดประกอบ ถ้าคุณไม่แน่ใจว่าติดตั้งชุดประกอบนี้ถูกต้องหรือไม่ ให้หาช่างผู้เชี่ยวชาญเป็นผู้ติดตั้ง

**1** Insert the trim plate into the hard case.

**2** Insert the sleeve into the trim plate.

**3** Insert the mounting bolt into the sleeve.   
\*1 When you stand the unit, be careful not to damage the fuse on the rear.   
\*1 เมื่อคุณตั้งชุดประกอบขึ้น ระวังอย่าทำให้ฟิวส์บริเวณส่วนท้ายเสียหาย

**4** Do the required electrical connections.   
ต่อสายไฟตามที่กำหนดไว้ทั้งหมด

Bend the appropriate tabs to hold the sleeve firmly in place.   
งอแผ่นเพื่อยึดปลอกให้ตอกันเข้าที่

### Removing the unit / การถอดชุดประกอบ

Before removing the unit, release the rear section.

ก่อนจะถอดชุดประกอบ ให้ปลดหน้าปัดส่วนท้ายก่อน

**1** Release the rear section.

**2** Release the front section.

**3** Insert the two handles, then pull them as illustrated so that the unit can be removed.   
ใส่คันบังคับ 2 อันลงในร่องสำหรับไขพื้นลวดดึงภาพ จากนั้น ให้เลื่อนชุดประกอบออกในขณะที่ค่อย ๆ ดึงคันบังคับทั้งสองอันออกจากกัน

### When using the optional stay /

เมื่อใช้ตัวยึดแบบเลือกได้

(สามารถเลือกเปิดค้างไว้ได้)

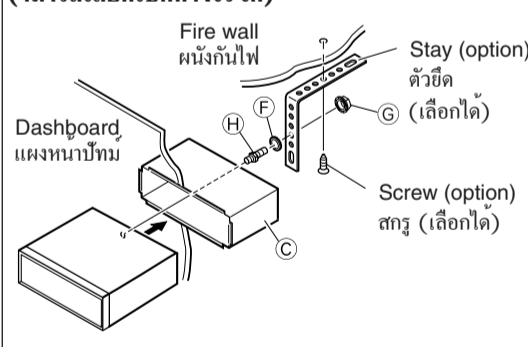

Install the unit at an angle of less than 30°.

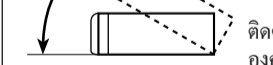

### When installing the unit without using the sleeve /

เมื่อติดตั้งชุดประกอบโดยไม่ใช้ปลอกหุ้ม

In a Toyota for example, first remove the car radio and install the unit in its place.

ตัวอย่างเช่น ในรถยนต์โตโยตา ให้ถอดวิทยุติดรถยนต์ออกก่อนและติดตั้งชุดประกอบนี้เข้าไปแทน

\* Not included with this unit.   
\* ไม่ได้ใหม่กับชุดประกอบนี้

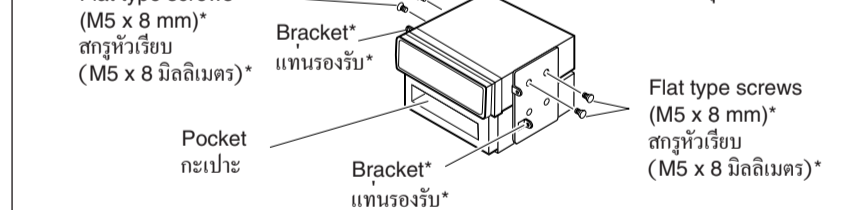

**Note** : When installing the unit on the mounting bracket, make sure to use the 8 mm-long screws. If longer screws are used, they could damage the unit.

**หมายเหตุ** : เมื่อติดตั้งชุดประกอบลงในแทนรองรับไว้ ให้ใช้สกรูยาวขนาด 8 มิลลิเมตร ถ้าใช้สกรูยาวกว่านี้อาจทำให้ชุดประกอบเสียหายได้

## TROUBLESHOOTING

- The fuse blows.**
  - Are the red and black leads connected correctly?
- Power cannot be turned on.**
  - Is the yellow lead connected?
- No sound from the speakers.**
  - Is the speaker output lead short-circuited?
- Sound is distorted.**
  - Is the speaker output lead grounded?
  - Are the “-” terminals of L and R speakers grounded in common?
- Noise interfere with sounds.**
  - Is the rear ground terminal connected to the car’s chassis using shorter and thicker cords?
- Unit becomes hot.**
  - Is the speaker output lead grounded?
  - Are the “-” terminals of L and R speakers grounded in common?
- This unit does not work at all.**
  - Have you reset your unit?

## การตรวจสอบปัญหาที่พบบ่อย

- ฟิวส์ขาด**
  - \* มีการเชื่อมสายตะกั่วสีดำและสีแดงอย่างถูกต้องหรือไม่
- ไม่สามารถเปิดเครื่องได้**
  - \* มีการเชื่อมสายตะกั่วสีเหลืองหรือไม่
- ไม่มีเสียงออกจากลำโพง**
  - \* สายตะกั่วส่วนที่ออกทางลำโพงเกิดไฟฟ้ลัดวงจรหรือไม่
- เสียงเพี้ยน**
  - \* สายตะกั่วส่วนที่ออกทางลำโพงต่อลงดินหรือไม่
  - \* สายขั้วลบ “-” ของลำโพงคานซ้ายและขวาต่อลงดินตามปกติหรือไม่
- เสียงรบกวน**
  - \* มีการใช้สายสั้นๆ หรือหนาๆ ต่อจากเครื่องส่วนที่ติดตั้ง ไว้บนพื้นด้านหลังกับตัวถังรถยนต์หรือไม่
- ชุดประกอบร้อนขึ้น**
  - \* สายตะกั่วส่วนที่ออกทางลำโพงต่อลงดินหรือไม่
  - \* สายขั้วลบ “-” ของลำโพงคานซ้ายและขวาต่อลงดินตามปกติหรือไม่
- เครื่องไม่ทำงานได้เลย**
  - \* ท่านได้ตั้งเครื่องใหม่หรือยัง

# ELECTRICAL CONNECTIONS

To prevent short circuits, we recommend that you disconnect the battery's negative terminal and make all electrical connections before installing the unit.

- Be sure to ground this unit to the car's chassis again after installation.

**Notes:**

- Replace the fuse with one of the specified rating. If the fuse blows frequently, consult your JVC car audio dealer.
- It is recommended to connect to the speakers with maximum power of more than 50 W (both at the rear and at the front, with an impedance of 4 Ω to 8 Ω). If the maximum power is less than 50 W, change "AMP GAIN" setting to prevent the speakers from being damaged (see page 25 of the INSTRUCTIONS).
- To prevent short-circuit, cover the terminals of the UNUSED leads with insulating tape.
- The heat sink becomes very hot after use. Be careful not to touch it when removing this unit.



## A Typical Connections

**Before connecting:** Check the wiring in the vehicle carefully. Incorrect connection may cause serious damage to this unit.

The leads of the power cord and those of the connector from the car body may be different in color.

- 1 Connect the colored leads of the power cord in the order specified in the illustration below.
- 2 Connect the antenna cord.
- 3 Finally connect the wiring harness to the unit.

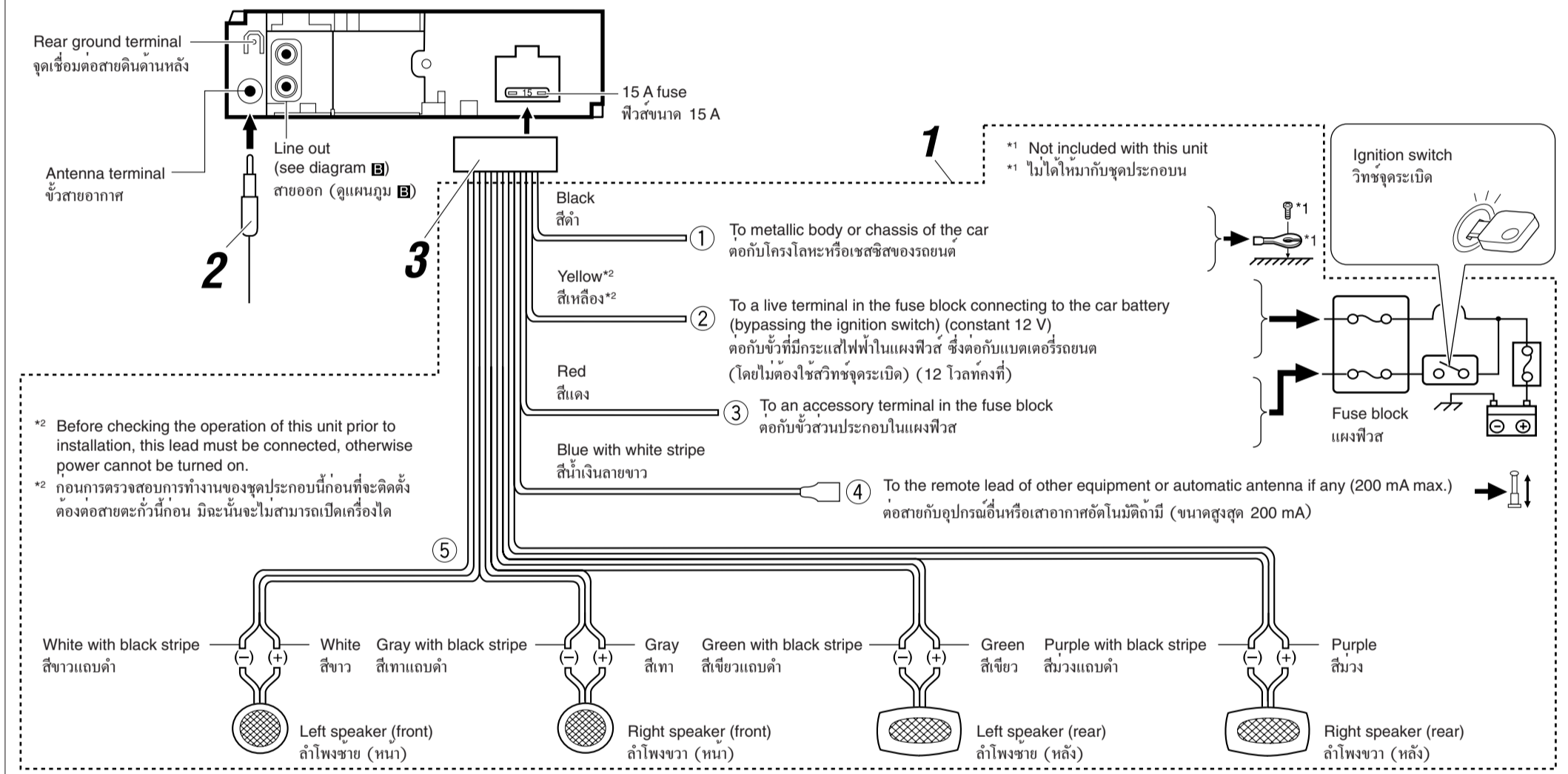

# การเชื่อมโดยใช้ไฟฟ้า

เพื่อป้องกันการเกิดไฟฟ้าลัดวงจรขอแนะนำให้ปลดขั้วแบตเตอรี่ลบออกแล้วจึงต่อสายไฟก่อนติดตั้งเครื่อง

- ตรวจสอบให้แน่ใจว่าได้เดินสายดินต่อระหว่างเครื่องกับตัวถัง รถยนต์ใหม่แล้วหลังจากติดตั้ง

**หมายเหตุ:**

- ใช้ฟิวส์เฉพาะแทนฟิวส์ หากฟิวส์ขาดบ่อย ให้ปรึกษาช่างขายเครื่องเสียงรถยนต์ JVC
- ขอแนะนำให้ต่อลำโพง ที่มีกำลังขับสูงสุดเกินกว่า 50 W (ทั้งด้านหน้าและด้านหลัง มีความต้านทาน 4 Ω ถึง 8 Ω) ถ้ากำลังขับต่ำกว่า 50 W ให้เปลี่ยนค่า "AMP GAIN" เพื่อป้องกันไม่ให้ลำโพงชำรุด (ดูหน้า 25 คำแนะนำ)
- การป้องกันการลัดวงจร จะต้องพันขั้วสายตะกั่ว ที่ไม่ใช้แล้วด้วยเทปพันสายไฟ
- แผ่นระบายความร้อนจะร้อนมากหลังจากใช้ ระวังอย่าไปสัมผัสเมื่อถอดชุดประกอบนี้

## การเชื่อมต่อแบบปกติ

**ถอดทำภาคเชื่อมต่อ:** ตรวจสอบการเดินสายไฟให้ถูกต้องอย่างระมัดระวังอย่าให้ผิดพลาดภาคเชื่อมต่อชุดประกอบชุดใดภาคเชื่อมต่อกผิดพลาดอาจทำให้เกิดความเสียหายแก่ชุดประกอบชุดใดภาคใดภาคของ ขั้วไฟ และของอุปกรณ์ต่อเชื่อมจากตัวถัง รถยนต์ที่มีที่ไม่เหมาะสม

- 1 ต่อสายไฟสีตามลำดับที่ระบุในรูปด้านล่าง
- 2 เชื่อมต่อกับสายอากาศ
- 3 สุดท้าย ต่อส่วนควบคุมการเดินสายไฟเข้ากับชุดประกอบชุดนี้

## B Connections Adding Other Equipment / การต่อเพิ่มเติมเข้ากับอุปกรณ์อื่น

### Amplifier / เครื่องขยาย

You can connect an amplifier and other equipment to upgrade your car stereo system.

- Connect the remote lead (blue with white stripe) to the remote lead of the other equipment so that it can be controlled through this unit.
- **Disconnect the speakers from this unit, connect them to the amplifier. Leave the speaker leads of this unit unused.**

คุณสามารถต่อกับแอมพลิฟายเออร์ และอุปกรณ์อื่น ๆ ได้ เพื่อเพิ่มคุณภาพเสียงให้กับระบบสเตอริโอของรถยนต์

- ต่อสายตะกั่วระยะไกล (สีน้ำเงินลายขาว) เข้ากับสายตะกั่วระยะไกลของอุปกรณ์อื่น ๆ เพื่อจะสามารถควบคุมโดยชุดประกอบนี้ได้
- สำหรับเครื่องขยายเท่านั้น: ถอดลำโพงออกจากชุดประกอบนี้ แล้วต่อเข้ากับเครื่องขยาย ทั้งสายตะกั่วลำโพงของชุดประกอบนี้ไว้

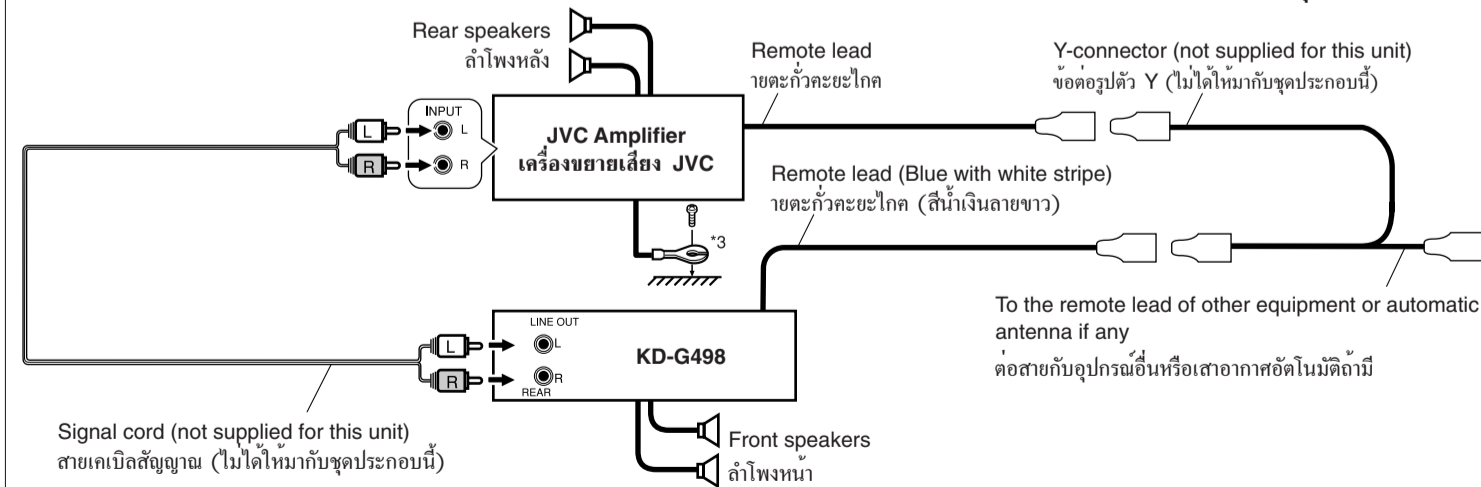

- \*3 Firmly attach the ground wire to the metallic body or to the chassis of the car—to the place not coated with paint (if coated with paint, remove the paint before attaching the wire). Failure to do so may cause damage to the unit.
- \*3 ต่อลวดสายดินใหม่แน่นเข้ากับตัวถังเหล็ก หรือตัวถังรถ — ตรงส่วนที่ไม่มีสีเคลือบ (หากมีสีเคลือบอยู่ ให้ขูดสีออกก่อนก่อนต่อลวดสายดิน) หากไม่ปฏิบัติตามคำแนะนำนี้ เครื่องอาจชำรุดหรือเสียหายได้

## PRECAUTIONS on power supply and speaker connections:

- DO NOT connect the speaker leads of the power cord to the car battery; otherwise, the unit will be seriously damaged.
- BEFORE connecting the speaker leads of the power cord to the speakers, check the speaker wiring in your car.

## ข้อควรระวังสำหรับการต่อแหล่งจ่ายกำลังและลำโพง:

- อย่าต่อสายตะกั่วเคเบิลกำลังของลำโพงเข้ากับแบตเตอรี่รถยนต์ มิฉะนั้น ชุดประกอบจะได้รับความเสียหายมาก
- ก่อนที่จะต่อสายตะกั่วเคเบิลกำลังของลำโพงเข้ากับลำโพง ให้ตรวจสอบการเดินสายไฟลำโพงในรถของคุณให้เรียบร้อยเสียก่อน

